

PHOS 65s pole mount – Specifications



item: PHOS 65s pole mount
 body: steel / aluminium
 weight: 4.1 kg
 environmental conditions: outdoors, humid interiors
 ambient temperature: -30° C – + 35° C
 cooling: active cooling, fan
 noise level: 33 dBA
 light source: 60 W High Power LED
 recommended projection distance in normal room light: 20 ft
 recommended projection distance in darkness: 50 ft
 average lifetime of the LED (L70): 25,000 hours
 colour temperature: 6,300 - 6,700 K
 luminous flux of the LED: 3,800 lumens
 gobo size / image size: Ø 50 mm / Ø 40 mm
 input voltage: 100 - 240 V AC, 50 / 60 Hz
 power consumption: 62 W
 efficiency: 0.8 cos. φ
 electrical protection: I
 ingress protection rating: IP 64
 photobiological safety according to ICE62471:2006 EN62471:2008: RG-2
 item number: 20065610 – white, 20065620 – black, 20065630 – silver

PHOS 65s pole mount is the most powerful outdoor system for mounting on poles and tubes. Its 60 watts, air-cooled High-Power LED provides uncompromised brightness, which guarantees a brilliant and crisp projection in almost any situation. PHOS 65s pole mount is the optimal solution, when projecting on coloured or dark surfaces or when colourful artworks are to be displayed. The projector is suitable for damp interiors or year-round outdoor use. The ballast is already integrated in the housing. The projector is connected via a watertight connection tube. The maximum projection distance is 20 feet in normal room lighting and 50 feet at dusk and night. Recommended application are: projections on facades or architectural elements, messages on pavements. Also vegetation and parks can be used as projection screen. The projection motif (gobo) can be changed without tools.

Components:

Standard series with high power LED and 85 mm standard lens. Required accessories: glass gobo with individually designed motif.



Dimensions

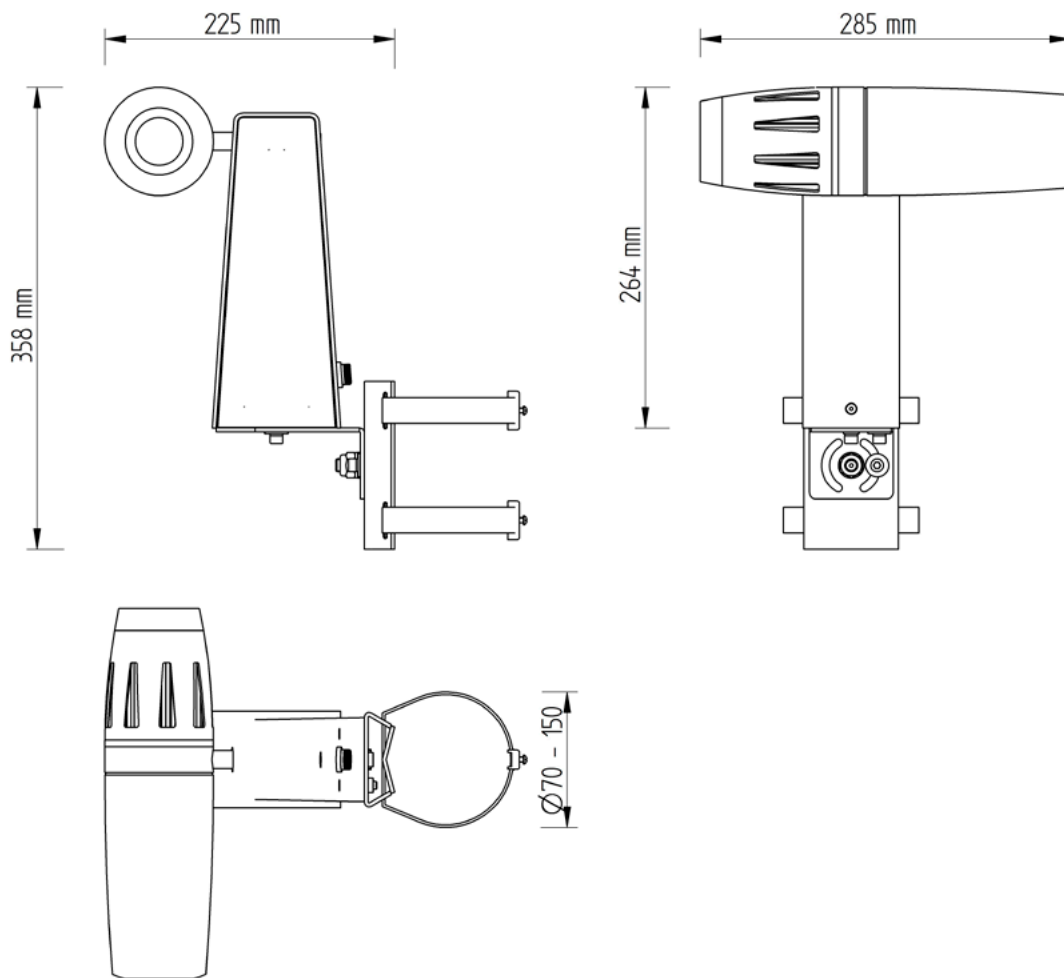

Projection Size

Standard Lens, $f = 85$ mm

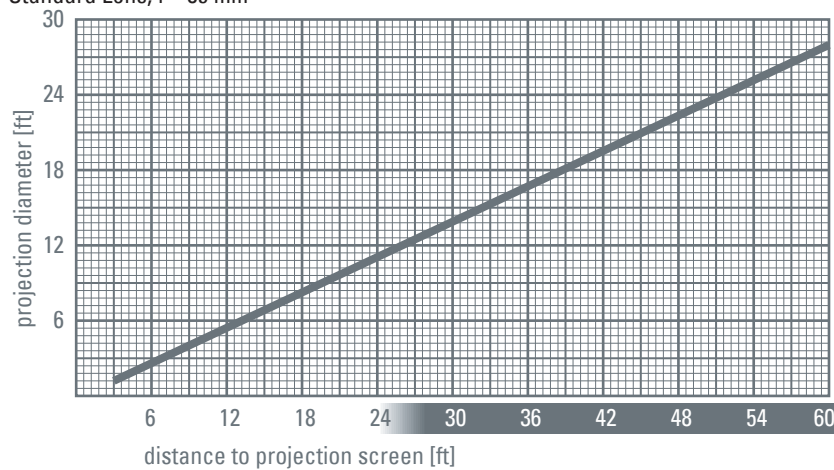

derksen®
lichttechnik

Derksen Lichttechnik GmbH
Sauerlandstraße 5
45889 Gelsenkirchen
Germany

Tel.: +49 (0)209 / 9 80 70 0
Fax: +49 (0)209 / 9 80 70 60

info@derksen.de
www.derksen.de

We reserve the right to make technical and optical modifications. Our general terms and conditions apply.